



bre

**Wind loading and impact testing on Joule VisSolis integrated Solar Thermal Collector to EN12975-2**

Prepared for:

Ronan Ginnell

Joule Energy Solutions

15<sup>th</sup> October 2010

Test report number 264-584/2

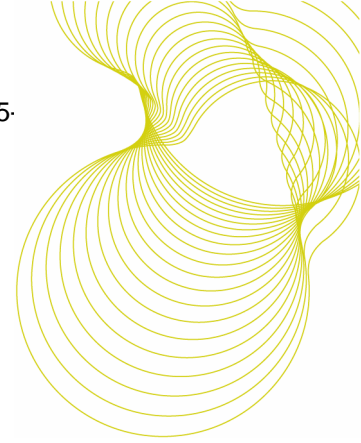

**Prepared by**

---

Name Dr P Blackmore  
Position Associate Director, Building Technology Group

Signature 

---

**Approved on behalf of BRE**

---

Name Mr D Richardson  
Position Director, Building Technology Group  
Date 15<sup>th</sup> October 2010

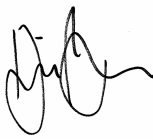
Signature 

---

BRE  
Garston  
WD25 9XX  
T + 44 (0) 1923 664000  
F + 44 (0) 1923 664010  
E [enquiries@bre.co.uk](mailto:enquiries@bre.co.uk)  
[www.bre.co.uk](http://www.bre.co.uk)

This report may only be distributed in its entirety and in accordance with the terms and conditions of the contract. Test results relate only to the items tested. BRE has no responsibility for the design, materials, workmanship or performance of the product or items tested. This report does not constitute an approval, certification or endorsement of the product tested.

This report is made on behalf of BRE. By receiving the report and action on it, the client – or any third party relying on it – accepts that no individual is personally liable in contract, tort or breach of statutory duty (including negligence).

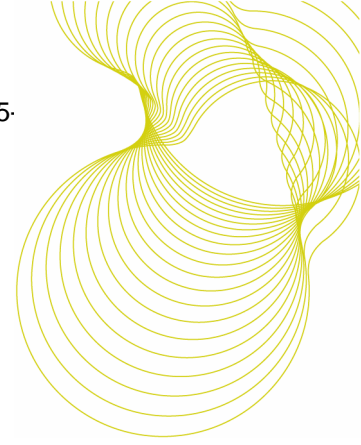

## Contents

1	Introduction	4
2	Details of the test specimens and the testing	5
2.1	Clause 5.9.1 Positive load test	5
2.2	Clause 5.9.2 Negative load test	5
2.3	Clause 5.10 Impact resistance test	6
3	Test results	7
3.1	Positive pressure loading test	7
3.2	Negative pressure loading test	9
3.3	Impact tests	11
5	Conclusions and Discussion	12
4	References	13
	Annex A Installation instructions for VisSolis solar collectors	14

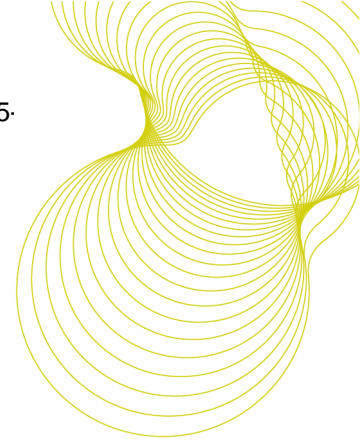

## 1 Introduction

This report describes mechanical load testing carried out to EN12975-2 to assess the wind loading and impact resistance of the Joule Energy VisSolis integrated solar thermal collector.

This report provides details of the testing carried out and results obtained from each test.

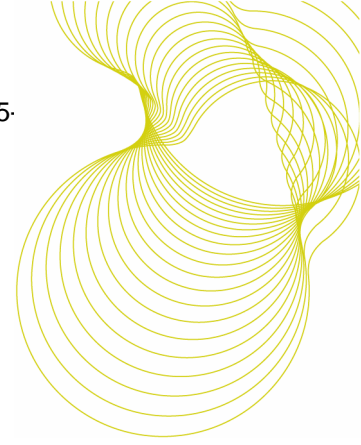

## 2 Details of the test specimens and the testing

BRE were supplied with two Joule Energy VisSolis roof integrated solar thermal collectors and the associated mounting and flashing kits. The serial numbers of the two collectors tested are:

Module 1: 201028-29 Used for upwards acting pressure testing

Module 2: 201028 -30 Used for hard body impact testing

Details of the module and fixing kit are included in the installation instructions for these collectors and are given in Annex A.

The testing was carried out according to the requirements of Clause 5.9 and Clause 5.10 of EN 12975-2 as follows:

### 2.1 Clause 5.9.1 Positive load test

Positive loading is a requirement of EN 12975-2. However, there is a note to Clause 5.9.1.4 which states '*When the test is done with an on-roof mounting system the test results are also valid for the roof integrated mounting system*'. BRE carried out the positive load test on the Joule Navitas Solar Thermal Collector in September 2010 (BRE report number 264-584/1). The Navitas solar collector is essentially identical to the VisSolis solar collector apart from the mounting kit and flashings. Therefore the results from the Navitas collector will be applicable to the VisSolis collector.

### 2.2 Clause 5.9.2 Negative load test

Negative loading was applied to a single solar thermal collector using pneumatic rams with suction cups attached in accordance with 5.9.2.2. The deflection of the mid point of the long and short sides of the collector frame and the centre of the glass cover sheet were measured during and after each load increment. Testing continued until failure of the collector occurred; which could be breakage of the cover glass or where the permanent deflection of the collector or fixings exceeds the specified limit, or where the limitations of the test rig are reached. The collector was attached to the roof using four angled brackets each with four screws and the flashings, see Annex A for details of the fixings. Figure 1 shows the specimen on the BRE test rig. Displacements were measured at the centre of the short edge (Location 1), the centre of the long edge (Location 2) and the centre of the glass cover sheet (Location 3).

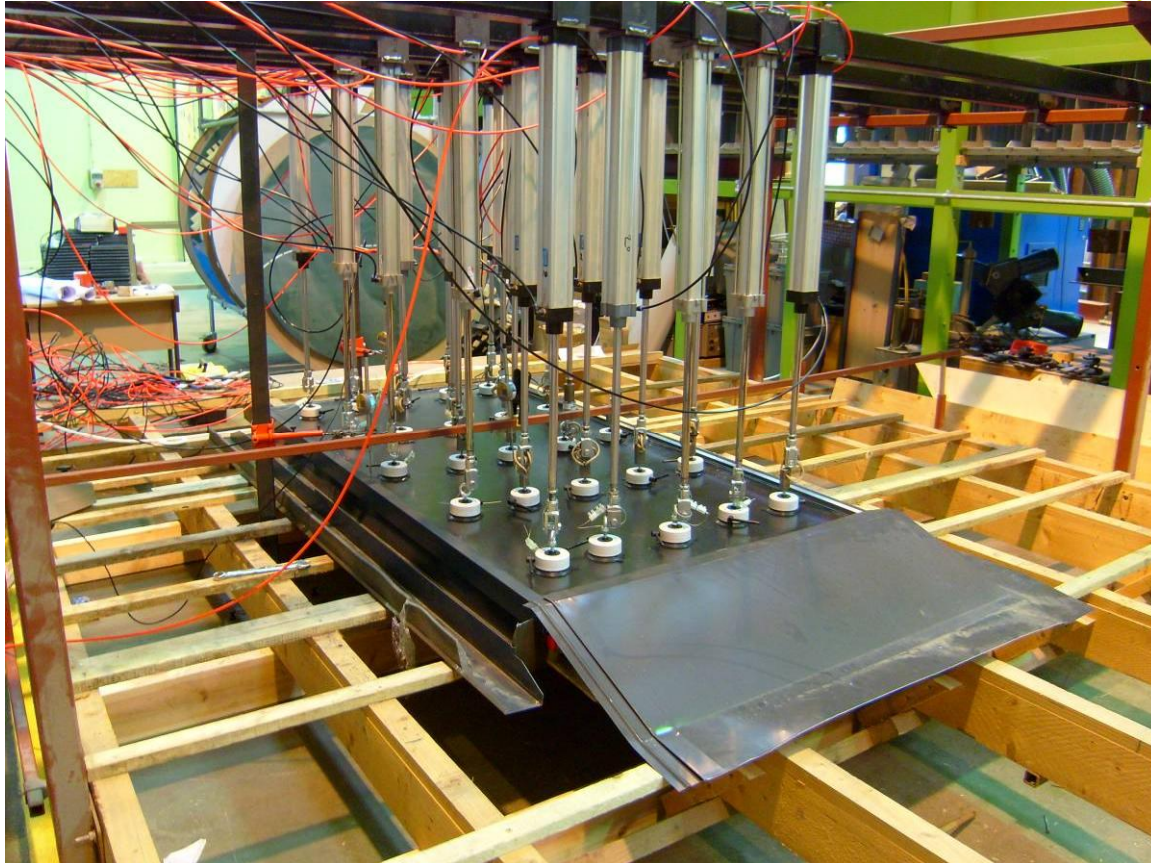
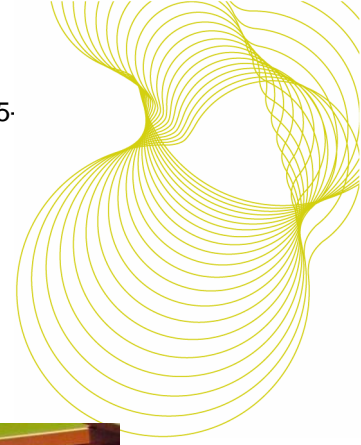
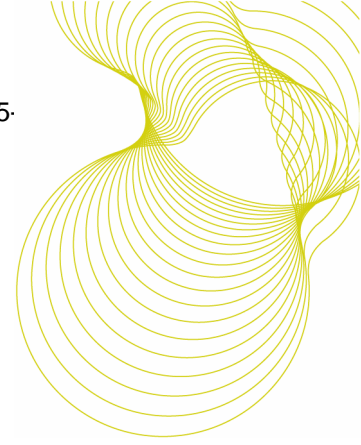

Figure 1 View of the BRE test rig and the test specimen ready for the negative pressure test

### 2.3 Clause 5.10 Impact resistance test

Tests were carried out using Method 1 of Clause 5.10. This method requires a steel ball of mass  $150g \pm 10g$  to be dropped on to the cover plate of the collector at a distance of no more than 5cm from the edge of the collector cover and no more than 10cm from the corner of the collector cover. The ball is moved a few millimetres between each impact. Impact drop heights of 0.4m, 0.6m, 0.8m, 1.0m, 1.2m, 1.4m, 1.6m, 1.8m and 2m were used, or until the specimen was damaged. The steel ball was dropped 10 times at each drop height and the impacts were distributed randomly around the four corners within the distance limitations described above.



### 3 Test results

#### 3.1 Positive pressure loading test

The results from the positive pressure tests on Navitas solar thermal collector are shown in Table 1 and Figures 2 and 3 for the maximum and residual displacement respectively.

Table 1 Load displacement results for Navitas solar thermal collector under positive loads

Load (Pa)	Maximum Displacement (mm)	Residual Displacement (mm)
227	3.07	0
453	13.82	0.21
680	17.7	0.33
907	20.19	0.41
1046	22.18	0.45
1273	24.45	0.57
1500	27.15	0.64
1727	29.41	0.79
1866	30.71	0.88
2093	32.75	0.87
2320	34.27	0.92
2546	36.42	0.99
2773	37.95	1.11
2912	39.99	1.11
3052	41.17	1.12
3279	42.7	1.13
3505	44.45	1.14
3732	46.98	1.16
3941	47.98	1.22
4168	49.09	1.23
4308	49.72	1.35
4534	51.89	1.36
4761	53.3	1.37
5040	55.1	1.39
5319	58.4	1.45

The Navitas solar collector withstood a positive pressure of 5319Pa. This was the limit of the BRE test rig. At this pressure there was no damage to the collector and it is likely that the collector will withstand higher pressures than this without damage. These results are also applicable to the VisSolis integrated solar collector because the collectors are essentially identical (as allowed by EN 12975-2 Clause 5.9.1.4). The maximum positive load is divided by a safety factor of 1.5 to obtain the permissible load under positive wind loading as specified in Clause 5.9.1.4

The permissible positive wind load for the VisSolis solar collector is therefore  $5319/1.5 = 3546\text{Pa}$

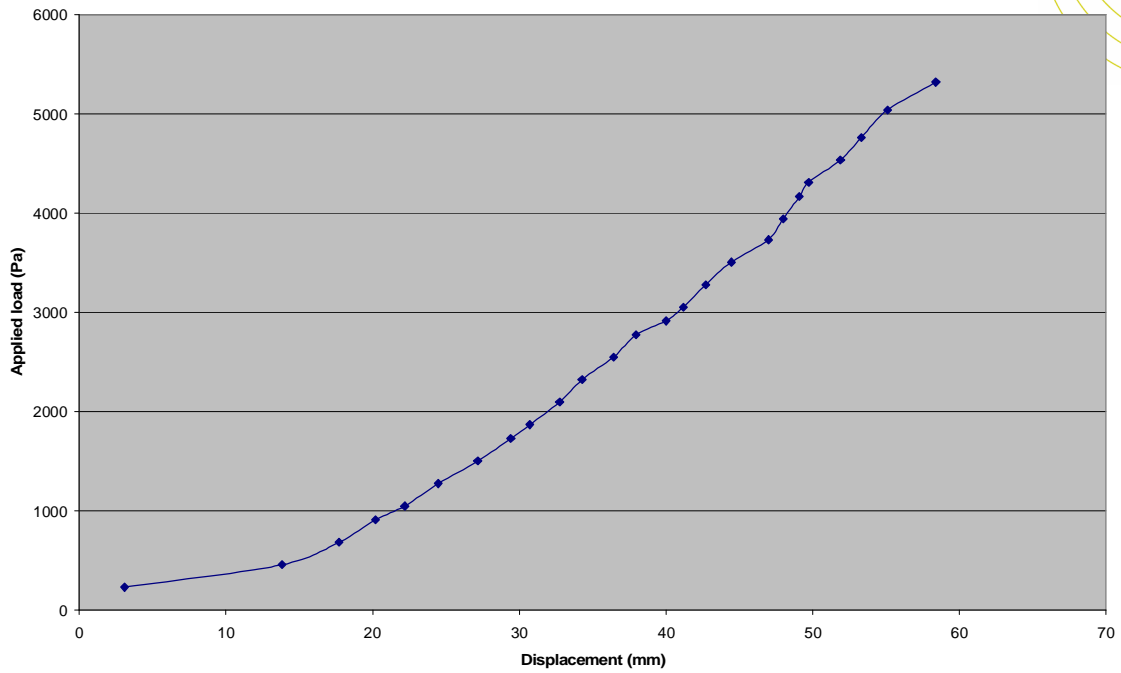
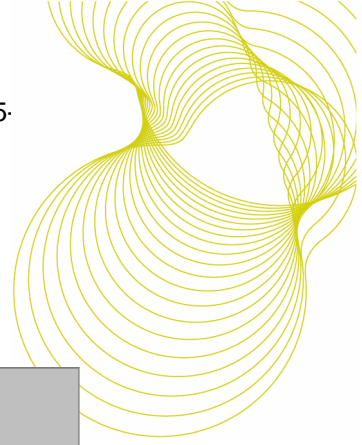

Figure 2 Plot of load versus maximum displacement for Navitas solar collector under positive loading

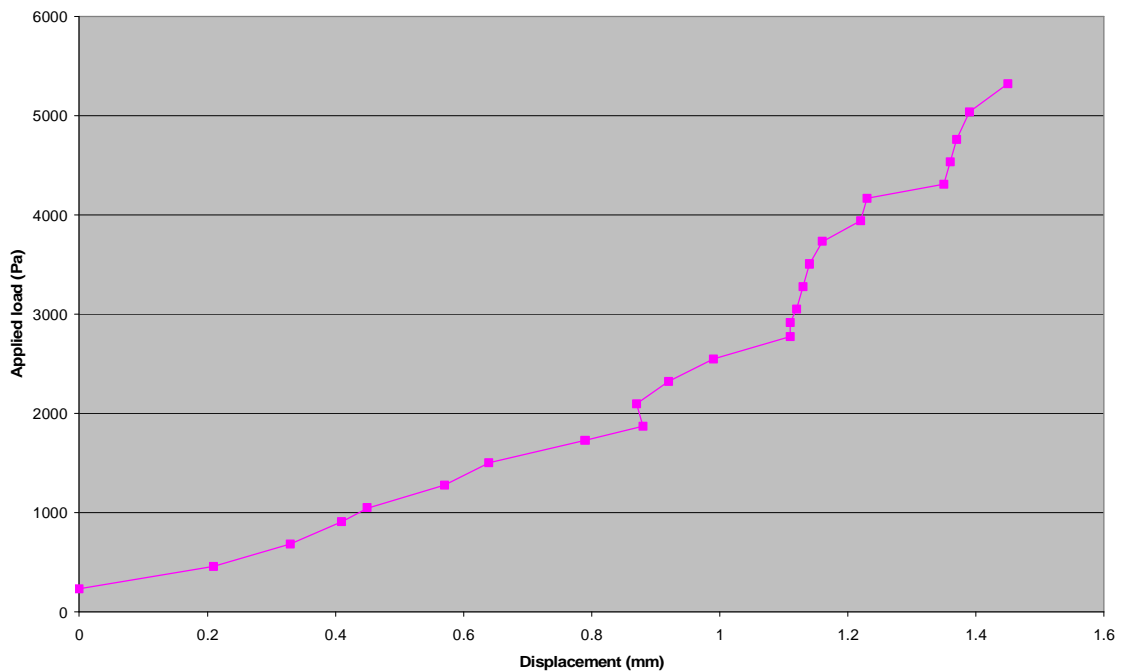
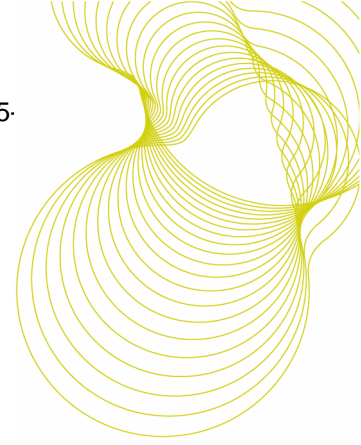

Figure 3 Plot of load versus residual displacement for Navitas solar collector under positive loading



### 3.2 Negative pressure loading test

The results from the negative pressure tests on the VisSolis solar thermal collector are shown in Table 2 and Figures 4 and 5 for the maximum and residual displacement respectively for measurements at Locations 1 and 3.

Table 2 Load displacement results for VisSolis solar thermal collector under negative loads

Load (Pa)	Maximum displacement (mm)			Residual displacement (mm)		
	Location 1	Location 2	Location 3	Location 1	Location 2	Location 3
0	0	0	0	0	0	0
245	1.81	1.45	34.81	0.01	0.1	0.53
380	2.34	1.76	40.51	0.08	0.22	1.11
552	3.14	2.23	47.09	0.14	0.26	1.187
650	3.88	2.63	52.93	0.23	0.3	1.45
797	4.47	2.96	56.24	0.24	0.33	1.5
907	5	3.24	59.41	0.26	0.33	1.4
1030	5.65	3.63	64.19	0.33	0.4	1.44
1300	6.69	4.24	69.66	0.4	0.45	1.84
1422	7.36	4.73	73.35	0.47	0.53	2.21
1533	8	5.18	76.46	0.51	0.62	2.29
1655	8.78	5.72	80.91	0.56	0.69	2.53
1827	9.75	6.25	85.22	0.63	0.76	2.45
2195	11.57	7.54	93.13	0.79	0.96	2.74
2256	11.97	7.8	94.97	0.83	1.01	3.25
2342	12.57	8.13	97.42	0.87	1.05	3.25
2453	13.26	8.62	100.58	0.91	1.08	2.99
2587	13.67	8.77	102.3	1.03	1.16	3.4
2784	14.78	9.45	106.83	1.19	1.29	3.92
3041	16.43	10.39	112.93	1.4	1.42	4.09
3213	17.56	10.88	117.49	1.63	1.53	4.53
3311	18.65	11.35	121.29	1.84	1.65	4.69
3532	19.67	11.8	124.74	2.05	1.73	4.89
3642	20.91	12.47	128.9	2.32	1.86	5.32

The VisSolis solar collector withstood a maximum negative pressure of 3532Pa. The failure mode was exceedance of the maximum residual deflection limit by the glass cover sheet. The allowable deflection limit is 0.5% of the length of the collector. As the smallest dimension of the collector is 1m then the maximum allowable permanent deflection is 5mm. The maximum load must be divided by a safety factor of 2.0 to obtain the permissible load under positive wind loading as specified in Clause 5.9.2.4

The permissible negative pressure for wind loads is therefore  $3532/2 = 1768\text{Pa}$

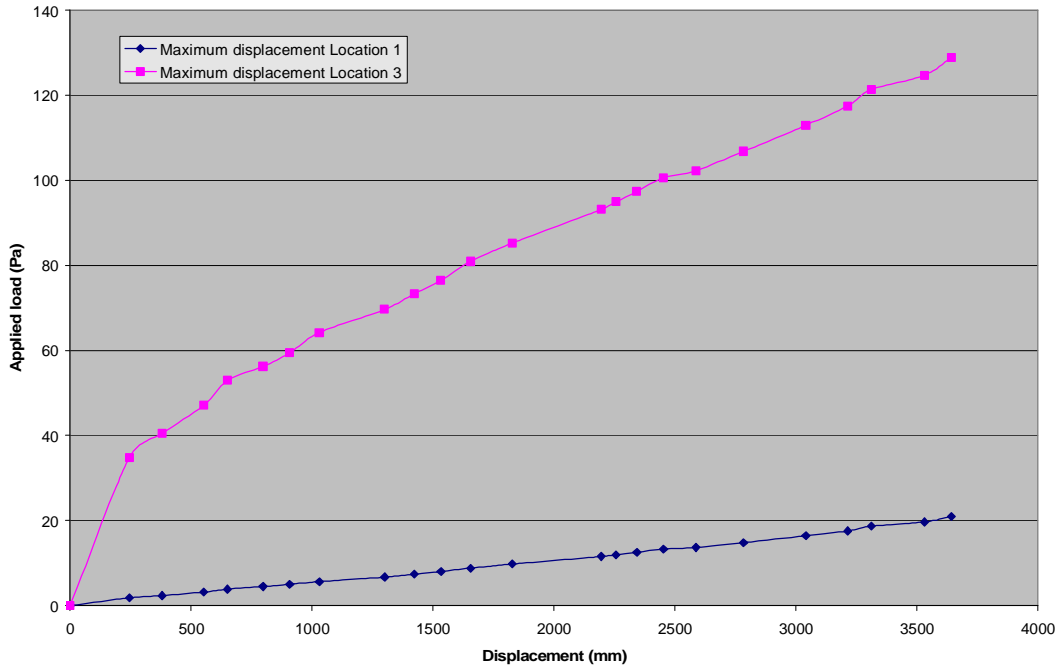

Figure 4 Plot of load versus maximum displacement for VisSolis solar collector under negative loading

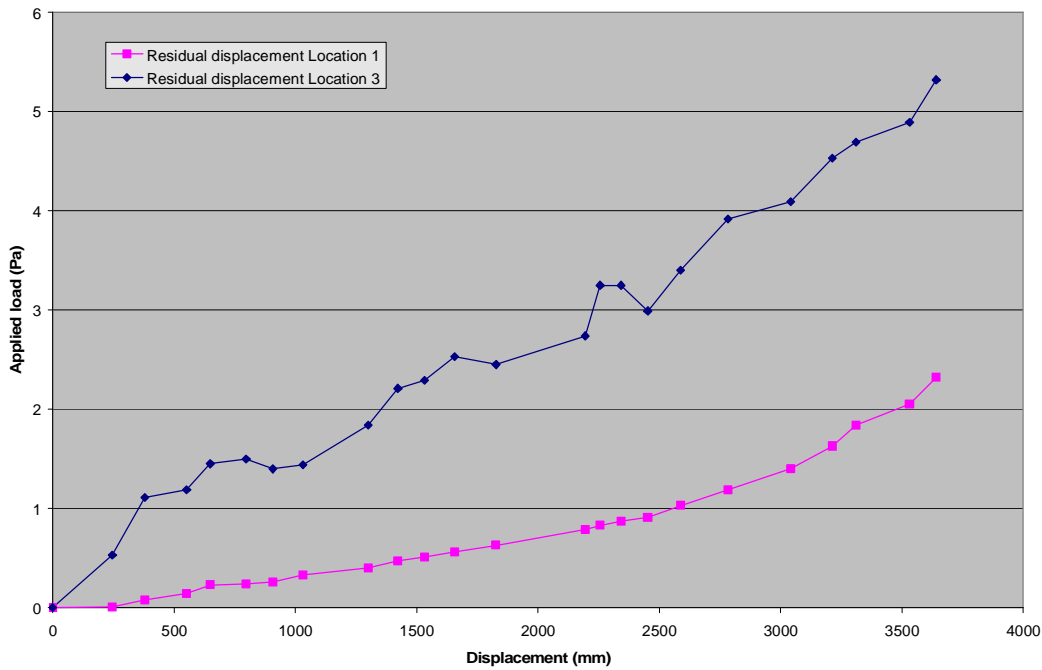
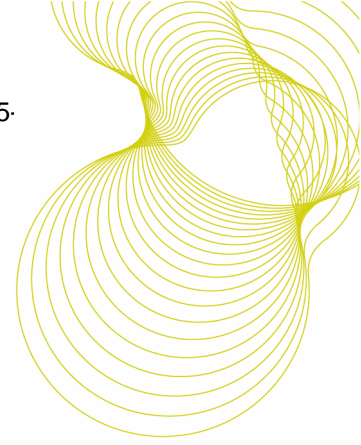

Figure 5 Plot of load versus residual displacement for VisSolis solar collector under negative loading



### 3.3 Impact tests

The VisSolis solar collector was impacted 10 times at each of the drop heights of 0.4m, 0.6m, 0.8m, 1.0m, 1.2m, 1.4m, 1.6m, 1.8m and 2m. The impacts at each drop height were randomly distributed around each of the four corners.

The collector survived all drop heights up to and including the maximum drop height of 2m. At the end of the testing there was no visible sign of any damage to the collector. Figure 6 shows the test specimen after completion of the impact testing.

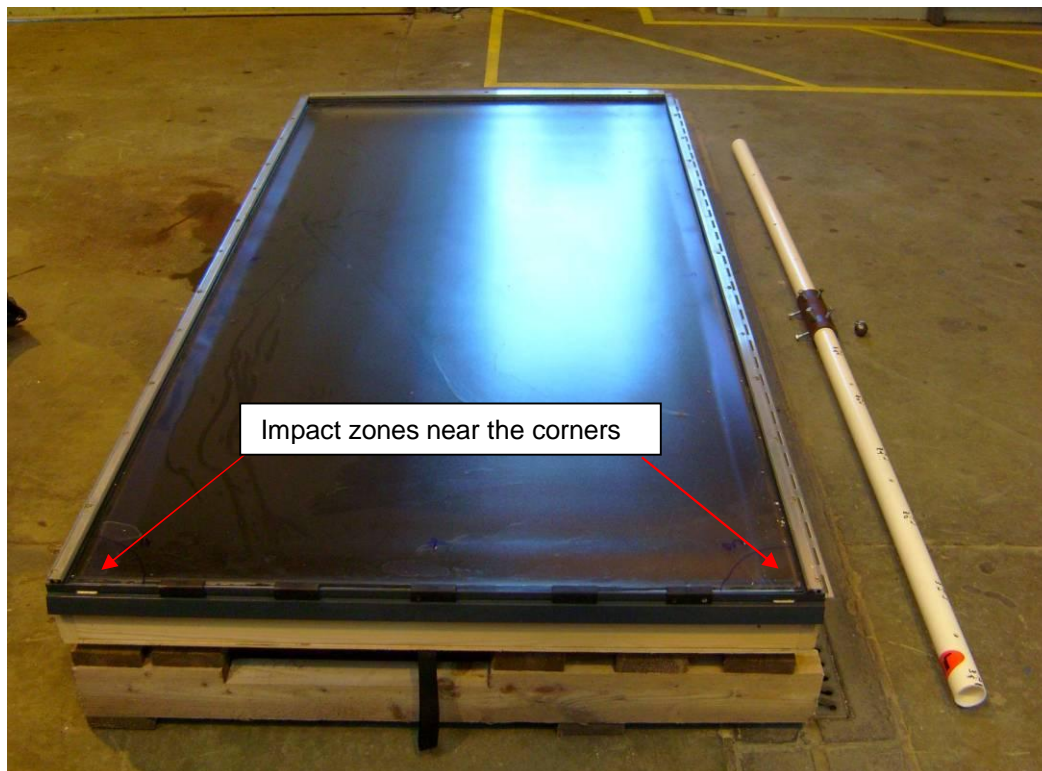
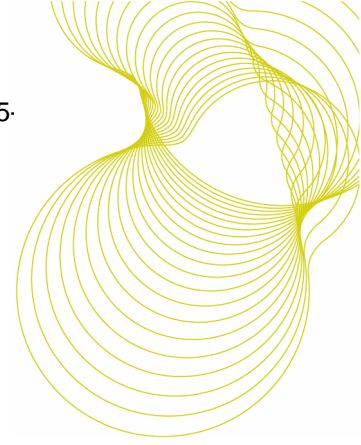

Figure 6 View of the collector after all impact testing has been completed



## 5 Conclusions and Discussion

This report describes tests carried out to assess the performance of the VisSolis solar thermal collectors under simulated wind loading (downwards and upwards acting wind loading) and impact loading carried out in accordance with the requirements of EN 12975-2.

The main conclusions from this study are as follows:

- i. Under positive (downwards acting pressure) the solar collectors will withstand a wind load of at least 5319Pa. The permissible downward acting wind pressure is 3546Pa (based on a factor of safety of 1.5).
- ii. Under negative (upwards acting pressure) the solar collectors will withstand a wind load of 3532Pa. The permissible upward acting (suction) wind pressure is 1768Pa (based on a factor of safety of 2).
- iii. The VisSolis integrated solar thermal collector will withstand hard body impacts from a 150g  $\pm$ 10g steel ball dropped 10 times from a height of 2m.

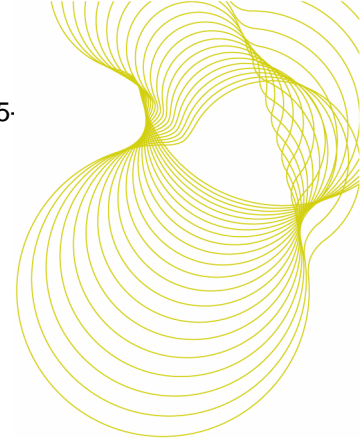

## 4 References

- 1 EN 12975 Part 2; Thermal solar systems and components — Solar collectors — Part 2: Test methods, 2006.



## Annex A Installation instructions for VisSolis solar collectors



### Installation instructions

Tools required:



Power drill with screwdriver bit



Rubber mallet



Tape measure



27 mm and 38 mm spanners

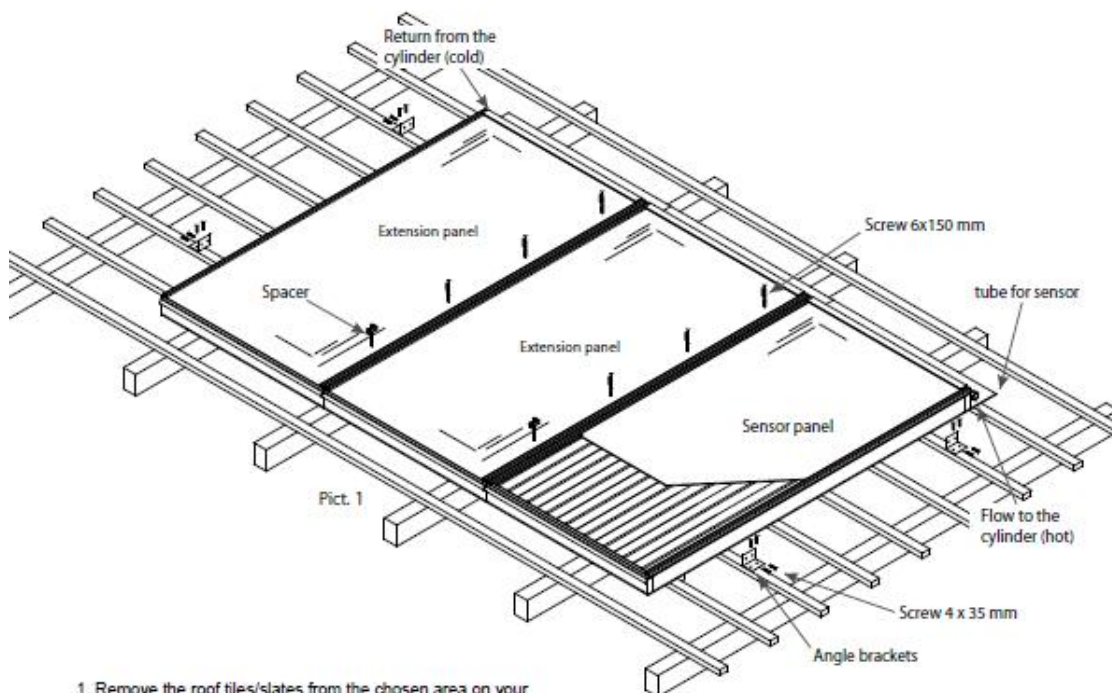

1. Remove the roof tiles/slates from the chosen area on your South facing roof where the panel/s will be placed. (Allow 1 m each side of the panels). Please note, that the upper part of the flashing should be at least 2 tile rows below the ridge!

2. There are straps to carry on the upper and under side of the panel. Never carry the panel by the connecting sockets!

3. First install the sensor panel on the right hand side of the array (this panel is marked with a sticker at the top right corner). Place the panels on the cleared part of the roof. On the back of each panel is a lath which hooks over a roofing batten. This prevents the panel from sliding down the roof until it is fixed.

4. Additional panels are placed on the roof. Slide them from the left side to the next panel until the joining edges interlink. (Pict. 2)

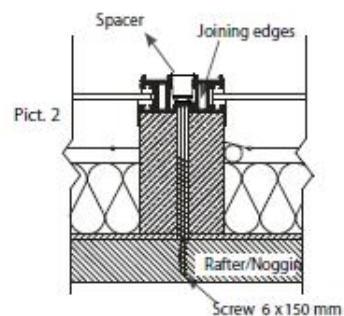

Page 1

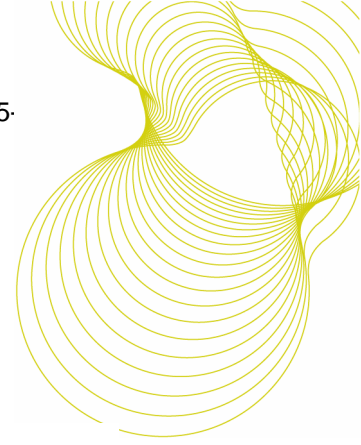

5. The hydraulic connection is made by connecting the unions between panels. Note! Care should be taken to avoid the connecting pipes rotating, which could damage the absorber in the panel!

6. Due to the internal design, the panels are connected in series. A variety of non-standard options are available for the flow and return connections.

**Note!** The panel on the right hand side is the hottest this is the flow to the cylinder. The panel on the left side is the return from the cylinder.

7. The panels should now be checked for leaks. Test to at least 12 bar with water/antifreeze. Every connection must be checked over a period of at least 20 minutes. **Note!** It is not possible to empty the panels. Always check with water/antifreeze mixture.

8. Fixing between panels is by means of 6x150 mm screws through the elongated holes in the aluminium profile to the roof rafters/noggins. Pict. 1+2.

**Note!** To get the right distance between the panels it is necessary to use the black spacers! Pict. 1+2+7



9. The outside panels are fixed on their edges to the roof rafters/noggins with the angle brackets. Pict. 1+3

10. The moulded covers are fitted with screws to the aluminium profile at the bottom of the panels to cover the gaps between the panels. Pict. 4

11. The middle aluminium cover strips can now be fitted. Pict. 5  
**Note!** The countersunk hole in the strips must be at the top! Tap with the rubber mallet until the cover strip clicks into place. The two side strips are mounted after fitting the flashing!

12. Fix the cover strips with the screws to the panel. Pict. 6

13. The panel sensor for the solar control (sensor with red cable) is inserted into the tube which is situated on the right hand panel in the marked position.

